



RPL201/RPL201H

Electric Pallet Truck 2.0T **LI-ION**
TECHNOLOGY

- More accurate operation mechanism;
- Moving parts hard-wearing;
- More stable travelling procedure;
- More convenient for maintenance.

EP EQUIPMENT CO.,LTD
www.ep-ep.com



Electric Pallet Truck 2.0T

RPL201/RPL201H

Distinguishing mark							
1.1	Manufacturer				EP		EP
1.2	Model designation				RPL201		RPL201H
1.3	Drive unit				Electrics		Electrics
1.4	Operator type				standing		standing
1.5	rated capacity	Q	kg		2000		2000
1.6	Load center distance	c	mm		600		600
1.8	Load distance	x	mm		916 / 982	937 / 1003	916 / 982 937 / 1003
1.9	Wheelbase	y	mm		1418	1438	1418 1438
Weight							
2.1	Service weight (include battery)		kg		630		630
2.2	Axle loading, laden driving side/loading side		kg		1020 / 1610		1020 / 1610
2.3	Axle loading, unladen driving side/loading side		kg		500 / 130		500 / 130
Types,Chassis							
3.1	Tyre type driving wheels/loading wheels				Polyurethane / Polyurethane		Polyurethane / Polyurethane
3.2	Tyre size, driving wheels (diameter×width)		mm		Φ230x75		Φ230x75
3.3	Tyre size, loading wheels (diameter×width)		mm		Φ85x70 / Φ83x115		Φ85x70 / Φ83x115
3.4	Tyre size, caster wheels (diameter×width)		mm		Φ130x55		Φ130x55
3.5	Wheels, number driving, caster/loading (x=drive wheels)		mm		1 x +2 / 4 / 1 x + 2 / 2		1 x +2 / 4 / 1 x + 2 / 2
3.6	Track width, front,driving side	b ₁₀	mm		510		510
3.7	Track width,rear,loading side	b ₁₁	mm		370 / 430 / 515		370 / 430 / 515
Dimensions							
4.4	Lift height	h ₃	mm		120		120
4.9	Height drawbar in driving position min./max.	h ₁₄	mm		1150 / 1470		1150 / 1470
4.15	Lowered height	h ₁₃	mm		85		85
4.19	Overall length	l ₁	mm		1860	1930	1860 1930
4.20	Length to face of forks	l ₂	mm		710		710
4.21	Overall width	b ₁ / b ₂	mm		730		730
4.22	Fork dimensions	s/ e/ l	mm		55x170x1150 55x170x1220		55x170x1150 55x170x1220
4.25	Distance between fork-arms	b ₅	mm		540 / 600 / 685		540 / 600 / 685
4.32	Ground clearance, center of wheelbase	m ₂	mm		30		30
4.34.1	Aisle width for pallets 1000 × 1200 crossways	Ast	mm		2523		2523
4.34.2	Aisle width for pallets 800 × 1200 lengthways	Ast	mm		2372		2372
4.35	Turning radius	Wa	mm		1700		1700
Performance data							
5.1	Travel speed, laden/ unladen	km/ h	km/h		5.5 / 6		9.0 / 12.0
5.2	Lifting speed, laden/ unladen		m/ s		0.050 / 0.054		0.050 / 0.054
5.3	Lowering speed, laden/ unladen		m/ s		0.067 / 0.054		0.067 / 0.054
5.8	Max. gradeability, laden/unladen		%		8 / 16		8 / 16
5.10	Service brake type				Electromagnetic		Electromagnetic
Electric-engine							
6.1	Drive motor rating S2 60 min		kW		1.6		2.5
6.2	Lift motor rating at S3 15%		kW		2.2		2.2
6.3	The maximum allowed size battery		mm		550*190*500		550*190*500
6.4	Battery voltage/nominal capacity K5		V/ Ah		24 / 210		24 / 210
6.5	Battery weight		kg		70		70
Addition data							
8.1	Type of drive control				AC		AC
10.5	Steering type				Electronic		Electronic
10.7	Sound pressure level at the driver's ear		dB (A)		74		74

If there are improvements of technical parameters or configurations, no further notice will be given.
The diagram shown may contain non-standard configurations.

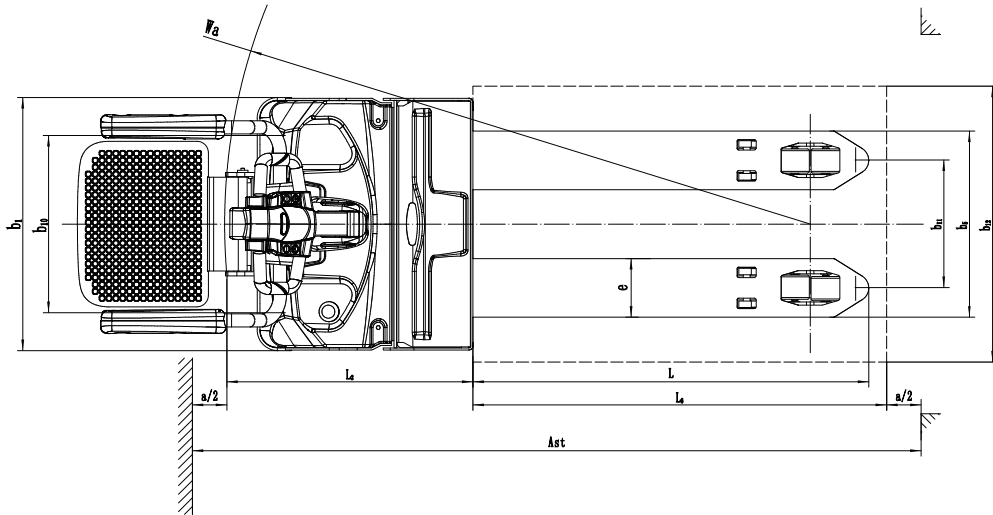
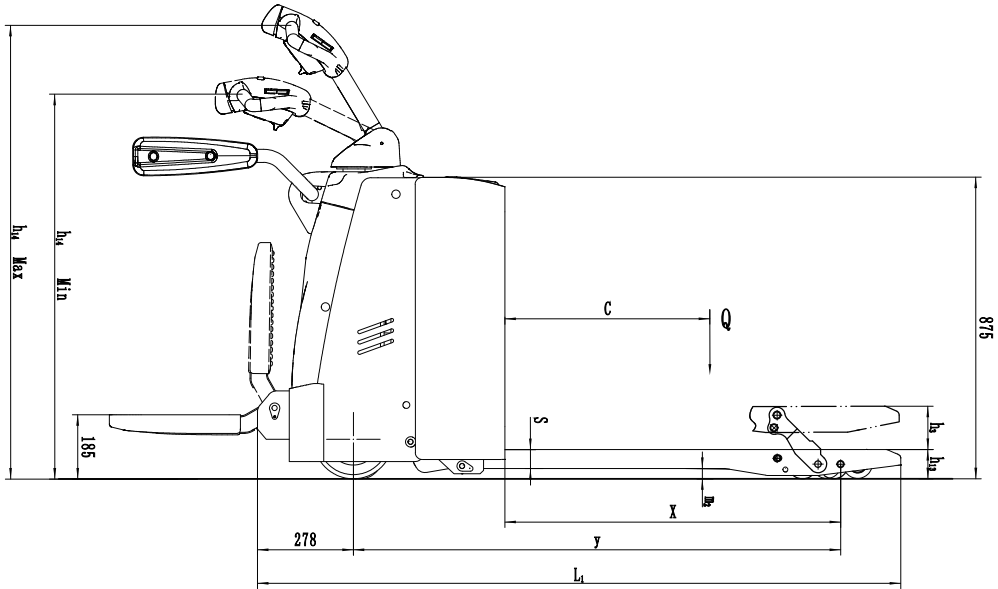

Option

Optional items	RPL201/RPL201H
Fork length	○1150/1220mm
Fork width	○540/600/685mm
Double load wheel	●
Single load wheel	●
Driving wheel	●PU
Balance wheel	● ○210AH
Lateral change battery	○210AH
half speed function in turning	●
Guard arm	●
Fork lowered height	●85mm
Special backrest	○1220mm (48in)/1520mm (60in)
Note:	● standard ○ option — NA